

RESOLUTION NO. 27354

A RESOLUTION AUTHORIZING UPTOWN VISION C/O DR. DAVE PIFER TO USE TEMPORARILY A PORTION OF RIGHT-OF-WAY LOCATED AT 629 MARKET STREET FOR THE INSTALLATION OF SIGNAGE, AS SHOWN ON THE ATTACHED MAPS, SUBJECT TO CERTAIN CONDITIONS.

---

BE IT RESOLVED BY THE CITY COUNCIL OF THE CITY OF CHATTANOOGA, TENNESSEE, that UPTOWN VISION c/o DR. DAVE PIFER, (hereinafter referred to as "Temporary User") be and is hereby permitted to use temporarily a portion of right-of-way located at 629 Market Street for the installation of signage, as shown on the attached maps.

BE IT FURTHER RESOLVED, that said temporary usage shall be subject to the following conditions:

1. Temporary User shall execute the Indemnification Agreement attached hereto in favor of the City of Chattanooga, its officers, agents and employees for any and all claims for damages for injuries to persons or property related to or arising out of the temporary usage.
2. Temporary User agrees to vacate the property and temporary use upon reasonable notice from the City to do so.
3. Temporary User shall provide adequate access for maintenance of any utilities located within the easement.
4. The proposed signage must meet the minimum elevation requirements as per City Codes and Standards.

ADOPTED: December 18, 2012

/ss

INDEMNIFICATION AGREEMENT

This Indemnification Agreement is entered into by and between THE CITY OF CHATTANOOGA, TENNESSEE (hereinafter the "City"), and UPTOWN VISION c/o DR. DAVE PIFER (hereinafter "Temporary User"), this 18<sup>th</sup> day of December, 2012.

For and in consideration of the granting of the temporarily a portion of right-of-way located at 629 Market Street for the installation of signage, as shown on the attached maps, subject to certain conditions, the receipt of which is hereby acknowledged, Temporary User agrees as follows:

1. Temporary User shall defend, and hold harmless the City of Chattanooga, Tennessee, its officers, agents and employees from any and all claims for damages for injuries to persons or property related to or arising out of the aforementioned temporary use.

2. Temporary User shall vacate the property and temporary use upon reasonable notice from the City to do so; the parties hereto agree that "reasonable notice" shall be deemed to be thirty (30) days. Temporary User shall restore the property to its original condition when it is returned to the City.

3. Temporary User shall provide adequate access for maintenance of any utilities located within the easement.

4. The proposed signage must meet the minimum elevation requirements as per City Codes and Standards.

UPTOWN VISION

\_\_\_\_\_, 2012  
Date

BY: \_\_\_\_\_  
Dr. Dave Pifer

12/20, 2012  
Date

CITY OF CHATTANOOGA, TENNESSEE

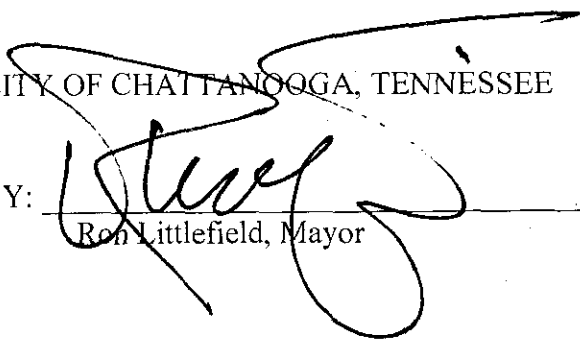
BY:   
Ron Littlefield, Mayor

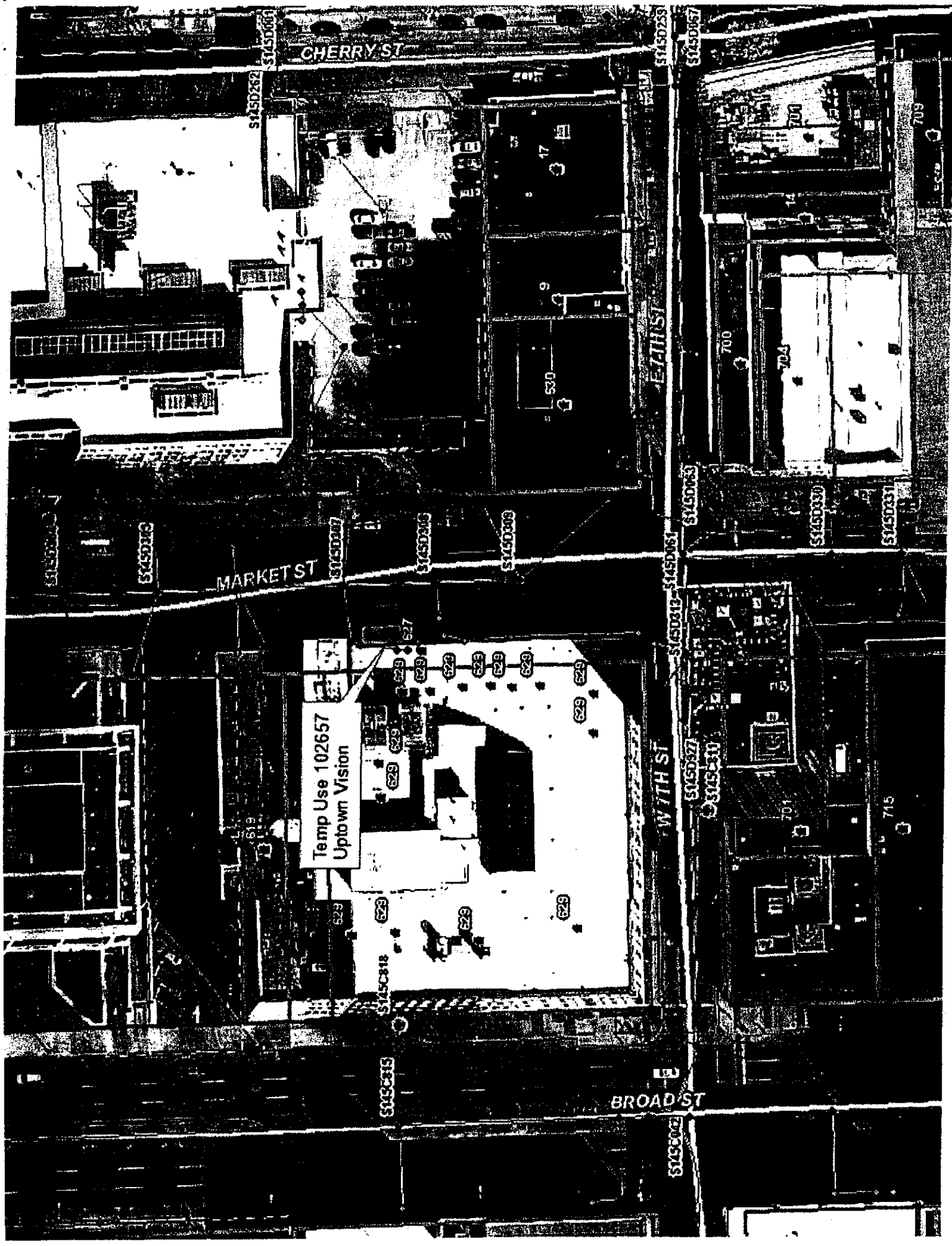

CHERRY ST

MARKET ST

BROAD ST

EAST ST

Temp Use 102657  
Uptown Vision

5145D262

5145D067

5145D258

5145D167

5145D116

5145D047

5145D116

5145D116

5145D161

5145D163

5145D330

5145D331

5145C818

5145C815

5145C002

5145D327

5145D330

629

629

629

629

629

629

629

629

629

629

629

629

629

701

715

700

704

709

9

17



2109 LAFAYETTE RD. • FT. OGLETHORPE, GA 30742 • PH: (706) 866-7999 • SALES FX: (706) 868-4400

JOB: UPTOWN VISION

MAIL:

ADDRESS:

LOC.: CHATTANOOGA, TN

SPACE#:

PRINT#: 28096-1

S. F. LENGTH:

SALESPERSON: A. KAPPY

CHANGE ORDER # A B C D E F

	INITIAL	TIME
RELEASED		
OPENING		
SHIP/TRIP		
INSTALL		
TARGET		
COMMIT		

SPECIAL INSTRUCTIONS:

EXTERIOR

QTY: 2

FACE: WHITE #7328 W/ METALLIC GOLD

#3630-131 VINYL OVERLAY

TRIMCAP: BLACK

RET COLOR: BLACK

RET DEPTH: 5"

LEDS: WHITE

LETTER STROKE: 4"

RACEWAY COLOR:

FASCIA CONST: AWNING

FASCIA COLOR:

VOLTAGE 110V

THIS DESIGN AND DRAWING IS IN THE PROPERTY OF VICTORY SIGN INC. NO TRANSMITTAL OR REPRODUCTION SHALL BE MADE TO ANY PERSON FROM OR CORPORATION WITHOUT PRIOR WRITTEN APPROVAL.

This Product is Licensed by  
**UNDERWRITERS LABORATORIES INC.**  
 and Bears the Mark:



DATE: 10/18/12

BY: NR

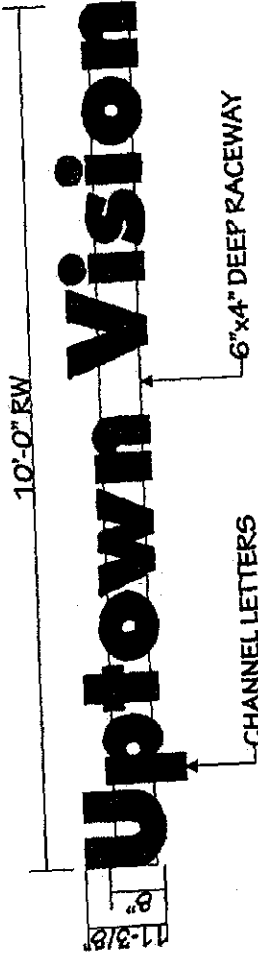

RACEWAY TO MOUNT ON TOP OF AWNING.

**\*\*NOTE:**  
 (1) SIGN TO HAVE ELECTRICAL COME OUT BEHIND THE "U"  
 (1) SIGN TO HAVE ELECTRICAL COME OUT BEHIND THE "N"

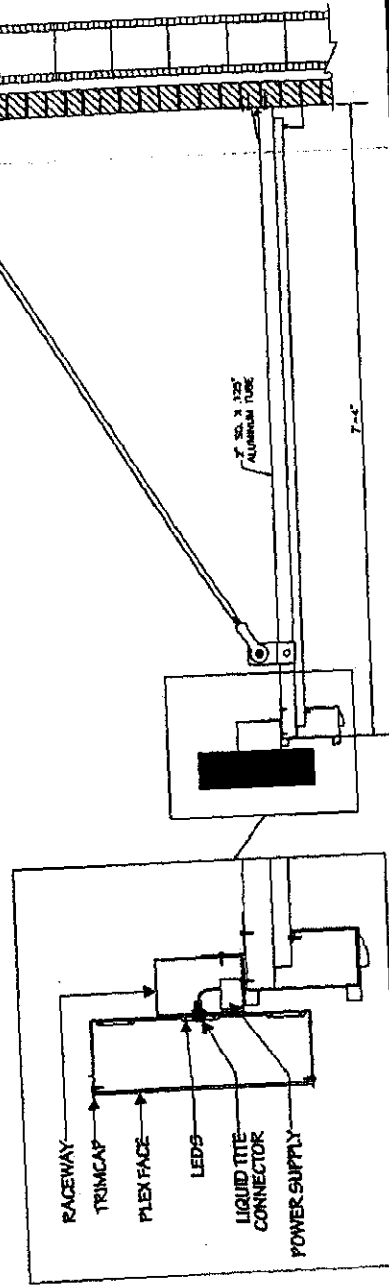

INSTALL IN ACCORDANCE WITH  
 THE NATIONAL ELECTRICAL CODE.

SCALE: 1/2" = 1'-0"

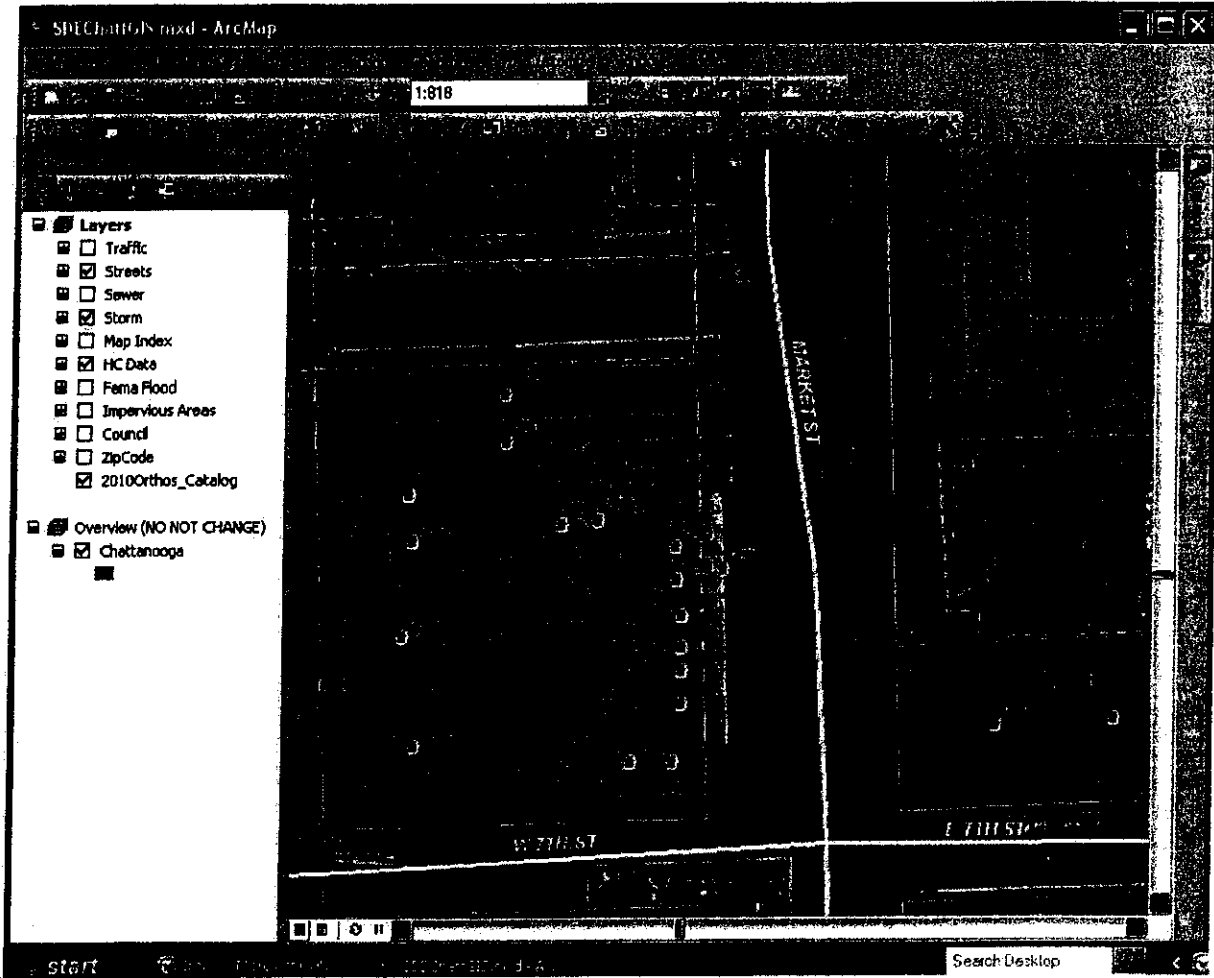

629 Market Street  
Temporary Use

UPTOWN VISION



2109 LAFAYETTE RD. • FT. OGLETHORPE, GA 30742 • PH: (706) 866-7999 • SALES FX: (706) 866-4400

JOB: UPTOWN VISION  
 MALL:  
 ADDRESS:  
 LOC.: CHATTANOOGA, TN  
 SPACE#:  
 PRINT#: 28096-1  
 S. F. LENGTH:  
 SALESPERSON: A. KAPRY

CHANGE ORDER #	A	B	C	D	E	F
RELEASED						
OPENING						
SHIP/TRIP						
INSTALL						
TARGET						
COMMIT						

SPECIAL INSTRUCTIONS:

EXTERIOR  
 QTY: 2

FACE: WHITE #7328 W/ METALLIC GOLD  
 #3630-131 VINYL OVERLAY  
 TRIMCAP: BLACK  
 RET COLOR: BLACK  
 RET DEPTH: 5"  
 LEDS: WHITE  
 LETTER STROKE: 4"

RACEWAY COLOR:

FASCIA CONST: AWNING  
 FASCIA COLOR:

VOLTAGE 110V

THIS DESIGN AND DRAWING SHOWN IS THE PROPERTY OF VICTORY SIGN INC. LTD. NO TRANSMITTAL OR DISCLOSURE SHALL BE MADE TO ANY PERSON, FIRM OR CORPORATION WITHOUT PRIOR WRITTEN APPROVAL.

This Product is Listed by  
 UNDERWRITERS LABORATORIES INC.  
 and Bears the Mark

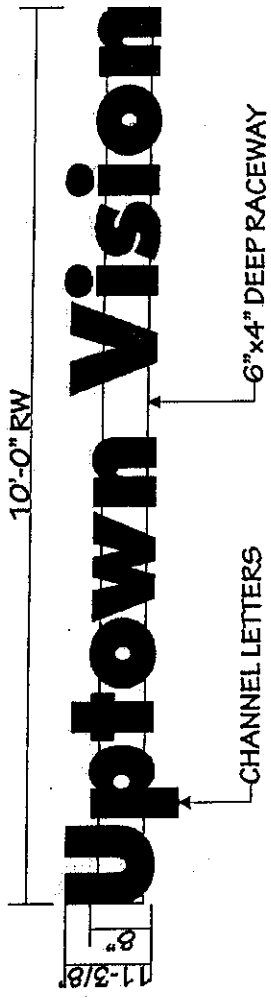

RACEWAY TO MOUNT ON TOP OF AWNING.

**\*\*NOTE:**  
 (1) SIGN TO HAVE ELECTRICAL COME OUT BEHIND THE "U"  
 (1) SIGN TO HAVE ELECTRICAL COME OUT BEHIND THE "N"

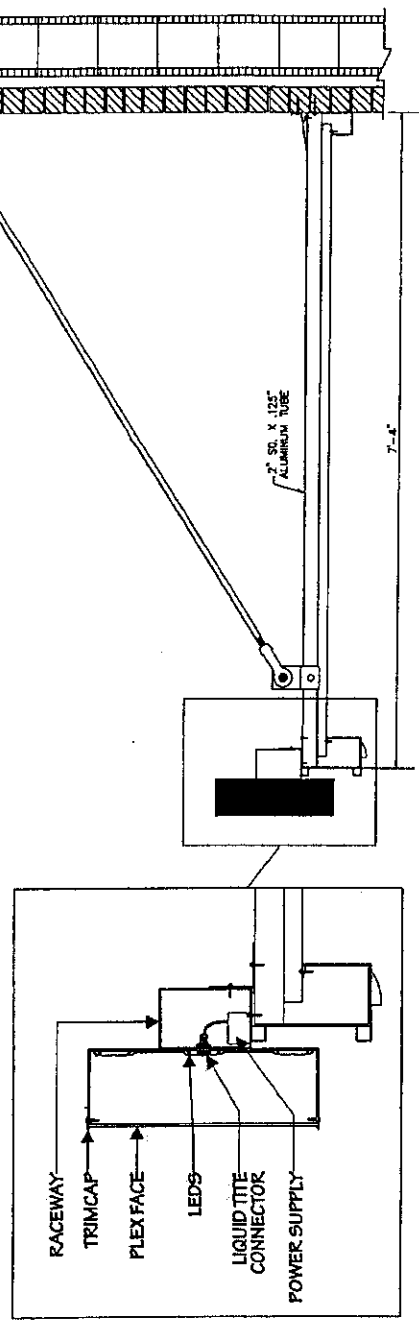

DATE: 10/18/12 BY: NR SCALE: 1/2" = 1'-0" INSTALL IN ACCORDANCE WITH THE NATIONAL ELECTRICAL CODE.

JOB: UPTOWN VISION  
 MALL:  
 ADDRESS:  
 LOC.: CHATTANOOGA, TN  
 SPACE#:  
 PRINT #: 28096-1&2  
 S. F. LENGTH:  
 SALESPERSON: A. KARPY

2109 LAFAYETTE RD. • FT. OGLETHORPE, GA 30742 • PH: (706) 866-7999 • SALES FX: (706) 866-4400



**SIGN ELEVATION**

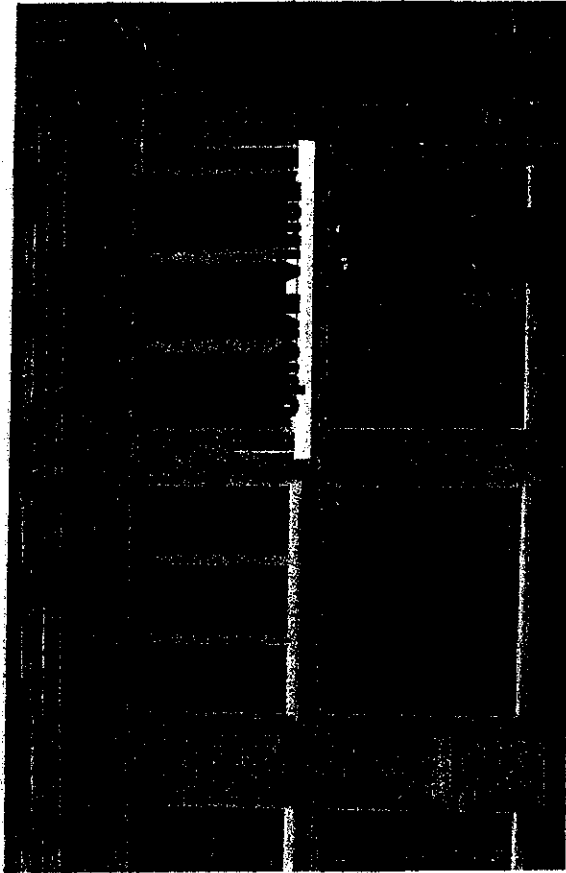

PRINT 1

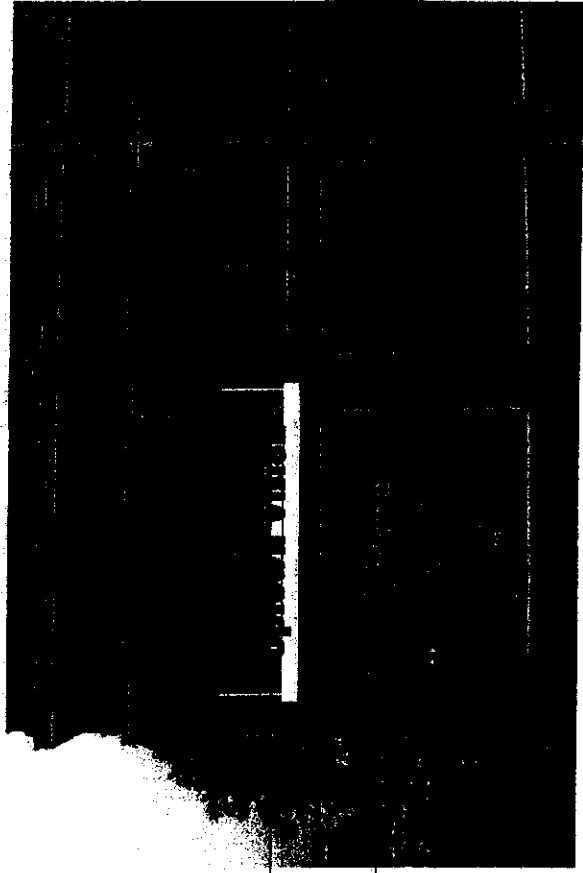

PRINT 1

PRINT 2

THIS DESIGN AND DRAWING SKETCH IS THE PROPERTY OF VICTORY SIGNING, LTD. NO TRANSMISSION OR DISCLOSURE SHALL BE MADE TO ANY PERSON, FIRM OR CORPORATION WITHOUT PRIOR WRITTEN APPROVAL.

DATE: 10/18/12

BY: NR

SCALE: NOT TO SCALE

VSI PRINTS: 28096-1&2 ELEV